

# + GHP

## 2-WAY HIGH PRESSURE BALL VALVES



### CARBON STEEL

- Type: ball valve GHP 2 way 
- Body: square
- Material: 1,0570/1,4404
- Ball seats: from DN13 up to DN80
- O-Rings: NBR, FKM, EPDM, MVQ
- Operating pressure: 370 Bar depending on valve size and seal materials selected
- Temp range: -20°C to +100°C depending on seal material selected

GHP	G 1/2		DN13	2	2	4	4	A	B
Type and way of valve	GAS DIN/ISO	NPT ANSI/ASME	Nominal dimension	Body material	Adapter material	Stem material	Ball material	Ball seat material	Adapter and stem seal material
GHP 2-way	228 BSP	B1.20.1							
	G 1/2	N 1/2	DN13	2 1,0570	2 1,0570	4 1,4404	4 1,4404	A POM	B NBR
	G 3/4	N 3/4	DN20			M 17-4PH		D PEEK	E FKM
	G 1	N 1	DN25					G PA612	F EPDM
	G 1 1/4 R	N 1 1/4 R	DN32					K GEMPTFE	L MVQ
	G 1 1/2 R	N 1 1/2 R	DN40					C PTFE	
	G 2	N 2	DN50						
	G 2 1/2	N 2 1/2	DN65						
	G 3	N 3	DN80						

### STAINLESS STEEL

- Type: ball valve GHP 2 way 
- Body: square
- Material: 1,4404
- Ball seats: from DN13 up to DN80
- O-Rings: NBR, FKM, EPDM, MVQ
- Operating pressure: 370 Bar depending on valve size and seal materials selected
- Temp range: -60°C to +230°C depending on seal material selected

GHP	G 1/2		DN13	4	4	4	4	A	B
Type and way of valve	GAS DIN/ISO	NPT ANSI/ASME	Nominal dimension	Body material	Adapter material	Stem material	Ball material	Ball seat material	Adapter and stem seal material
GHP 2-way	228 BSP	B1.20.1							
	G 1/2	N 1/2	DN13	4 1,4404	4 1,4404	4 1,4404	4 1,4404	A POM	B NBR
	G 3/4	N 3/4	DN20			M 17-4PH		D PEEK	E FKM
	G 1	N 1	DN25					G PA612	F EPDM
	G 1 1/4 R	N 1 1/4 R	DN32					K GEMPTFE	L MVQ
	G 1 1/2 R	N 1 1/2 R	DN40					C PTFE	
	G 2	N 2	DN50						
			DN65						
			DN80						

GHP





# 2-WAY HIGH PRESSURE BALL VALVES

Specialist in Ball Valves

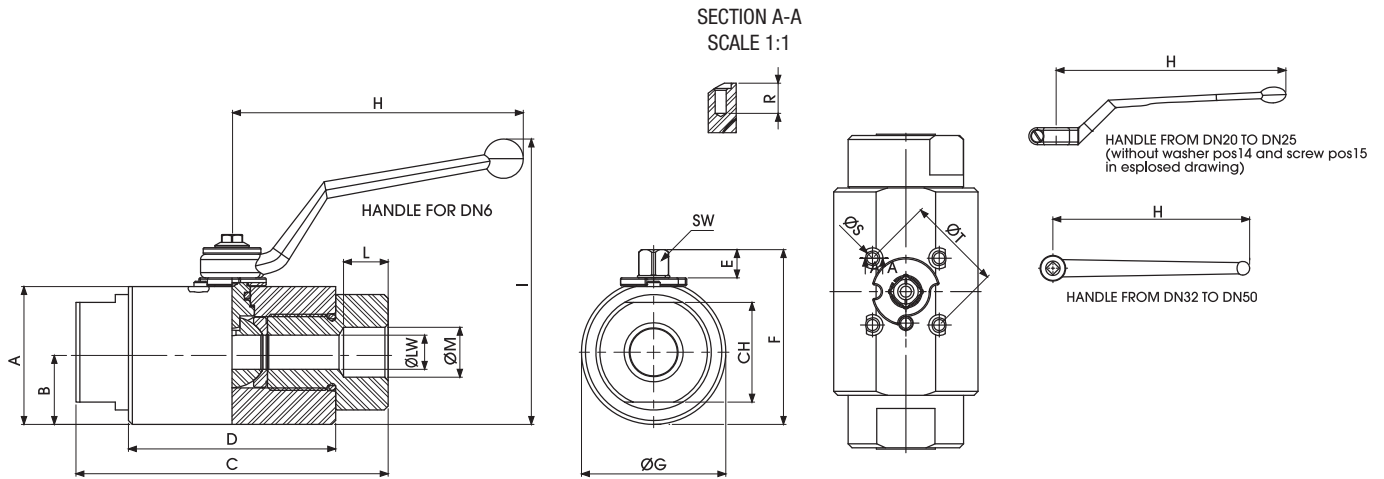

## GHP DIN/ISO 228 BSP

Standard

																				CARBON STEEL	STAINLESS STEEL		
TYPE	PN	DN	A	B	C	D	E	F	ØG	H	I	L	ØM	CH	ØT	ISO5211	ØS	R	SW	ØLW	KG	ITEM CODE	ITEM CODE
GHP G 1/2	37 MPa	13	53	27,5	119	79	11	66,5	55	110	102,5	17	G 1/2	38	36	F03	M5	9	9	13	1,81	GH2GGT3H024A000	GH2GGT3H044A000
GHP G 3/4	37 MPa	20	70	38,5	149	99	14	88,6	77	180	118	21	G 3/4	55	50	F05	M6	9	14	20	4,378	GH2GGT4H024A000	GH2GGT4H044A000
GHP G 1	37 MPa	25	80,5	45	168	105	14	99	90	180	129	24	G 1	60	50	F05	M6	9	14	25	6,219	GH2GGT5H024A000	GH2GGT5H044A000
GHP G 1 1/4	37 MPa	32	95	48,5	156	106	14	113	97	300	112	25	G 1 1/4	70	50	F05	M6	9	17	32	6,74	GH2GGT6H024A000	GH2GGT6H044A000
GHP G 1 1/2	37 MPa	40	111,5	58	166,5	110,5	14	130	116	300	128	25	G 1 1/2	75	50	F05	M6	9	17	40	10	GH2GGT7H024A000	GH2GGT7H044A000
GHP G 2	37 MPa	50	118,5	61,5	175	115	14	137	123	300	137	27	G 2	85	50	F05	M6	9	17	49	11,169	GH2GGT8H024A000	GH2GGT8H044A000
GHP G 2 1/2	37 MPa	65	184,5	93,5	211,5	131,5	30,5	223,5	187	600	280	32	G 2 1/2	140	102	F10	M10	20	24	63	36,5	GH2GGT9H02PA000	GH2GGT9H04NA000
GHP G 3	37 MPa	80	200	102	239	162,5	30,5	239	204	600	294	32	G 3	140	102	F10	M10	20	24	74	46,5	GH2GGTAH02PA000	GH2GGTAH04NA000

# + GHP

## 2-WAY HIGH PRESSURE BALL VALVES

www.gemels.it

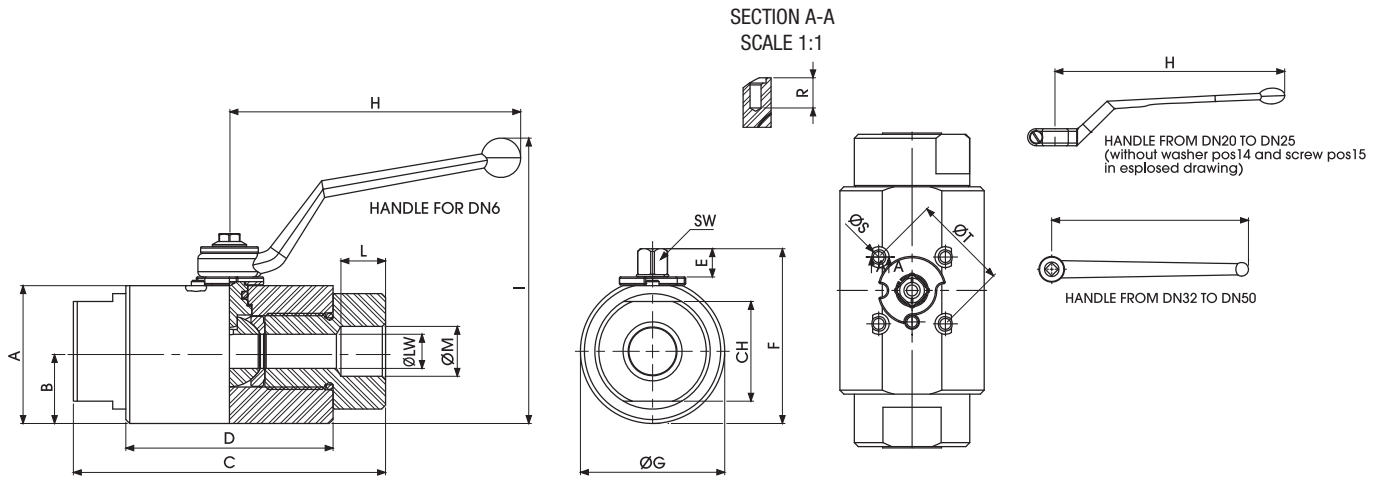

### GHP ANSI-ASME B1.20.1 NPT

Standard

																				CARBON STEEL	STAINLESS STEEL		
TYPE	PN	DN	A	B	C	D	E	F	ØG	H	I	L	ØM	CH	ØT	ISO5211	ØS	R	SW	ØLW	KG	ITEM CODE	ITEM CODE
GHP N 1/2	37 MPa	13	53	27,5	119	79	11	66,5	55	110	102,5	17	N 1/2	38	36	F03	M5	9	9	13	1,81	GH2NNT3H024A000	GH2NNT3H044A000
GHP N 3/4	37 MPa	20	70	38,5	149	99	14	88,6	77	180	118	21	N 3/4	55	50	F05	M6	9	14	20	4,378	GH2NNT4H024A000	GH2NNT4H044A000
GHP N 1	37 MPa	25	80,5	45	168	105	14	99	90	180	129	24	N 1	60	50	F05	M6	9	14	25	6,219	GH2NNT5H024A000	GH2NNT5H044A000
GHP N 1 1/4	37 MPa	32	95	48,5	156	106	14	113	97	300	112	25	N 1 1/4	70	50	F05	M6	9	17	32	6,74	GH2NNT6H024A000	GH2NNT6H044A000
GHP N 1 1/2	37 MPa	40	111,5	58	166,5	110,5	14	130	116	300	128	25	N 1 1/2	75	50	F05	M6	9	17	40	10	GH2NNT7H024A000	GH2NNT7H044A000
GHP N 2	37 MPa	50	118,5	61,5	175	115	14	137	123	300	137	27	N 2	85	50	F05	M6	9	17	49	11,169	GH2NNT8H024A000	GH2NNT8H044A000
GHP N 2 1/2	37 MPa	65	184,5	93,5	211,5	131,5	30,5	223,5	187	600	280	32	N 2 1/2	140	102	F10	M10	20	24	63	36,5	GH2NNT9H02PA000	GH2NNT9H04NA000
GHP N 3	37 MPa	80	200	102	239	162,5	30,5	239	204	600	294	32	N 3	140	102	F10	M10	20	24	74	46,5	GH2NNTAH02PA000	GH2NNTAH04NA000

# + GHP

## 2-WAY HIGH PRESSURE BALL VALVES

www.gemels.it

2015 - Edition 3

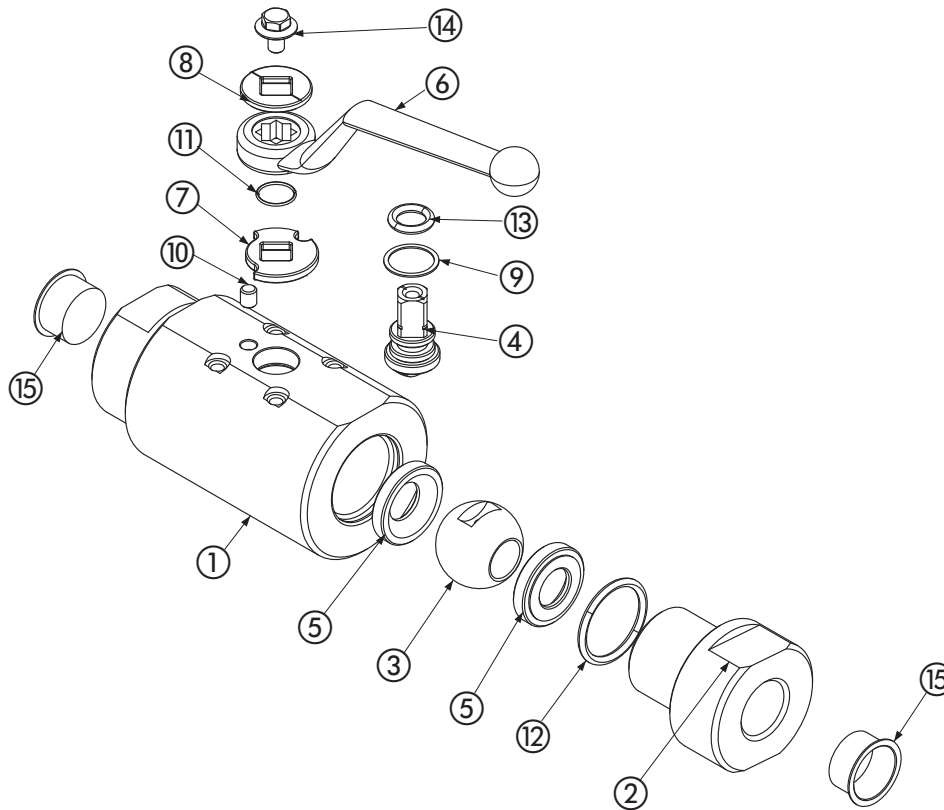

### Carbon steel

Pos	Description	Material	Q.tà
1	Body	1,0570	1
2	Adapter	1,0570	1
3	Ball	1,4404	1
4	Stem	1,4404	1
5	Ball seat	POM	2
6	Handle	ZINC	1
7	Washer	1,0116	1
8	Washer	1,0116	1
9	Stem ring	POM	1
10	Spine	1,0737	1
11	Seeger	1,4301	1
12	Adapter o-ring	NBR	1
13	Stem o-ring	NBR	1
14	Screw	Din 6921 8.8	1
15	Caps	PVC	2

- On request**
- Reduced bore
  - O-Ring in FKM, EPDM, HNBR, KALREZ
  - Seals in PTFE, PEEK, PA612, GEMPTFE, METAL TO METAL
  - Special threads
  - Pressure class up to PN37 Mpa
  - Pneumatic and electrical actuator
  - Locking device

*For further special requests please consult our technical/commercial service*

### Stainless steel

Pos	Description	Material	Q.tà
1	Body	1,4404	1
2	Adapter	1,4404	1
3	Ball	1,4404	1
4	Stem	1,4404	1
5	Ball seat	POM	2
6	Handle	ZINC	1
7	Washer	1,4301	1
8	Washer	1,4301	1
9	Stem ring	POM	1
10	Spine	1,4301	1
11	Seeger	1,4301	1
12	Adapter o-ring	NBR	1
13	Stem o-ring	NBR	1
14	Screw	Din 6921 A2	1
15	Caps	PVC	2

- On request**
- Reduced bore
  - O-Ring in FKM, EPDM, HNBR, KALREZ
  - Seals in PTFE, PEEK, PA612, GEMPTFE, METAL TO METAL
  - Special threads
  - Pressure class up to PN37 Mpa
  - Pneumatic and electrical actuator
  - Locking device