

# + Actuators

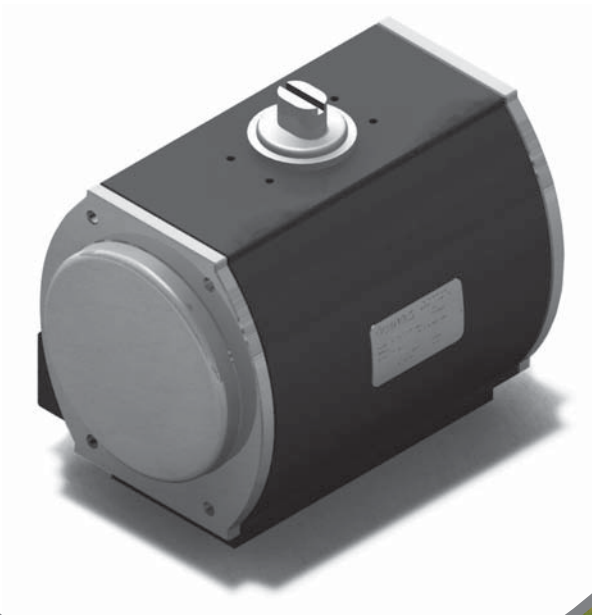

## **GEMELS PNEUMATIC ACTUATORS**

**INSTALLATION, OPERATION  
AND MAINTENANCE  
TECHNICAL DETAILS**  
Quarter-Turn Rack & Pinion

Actuators



# + Actuators

Specialist in Ball Valves

## Introduction

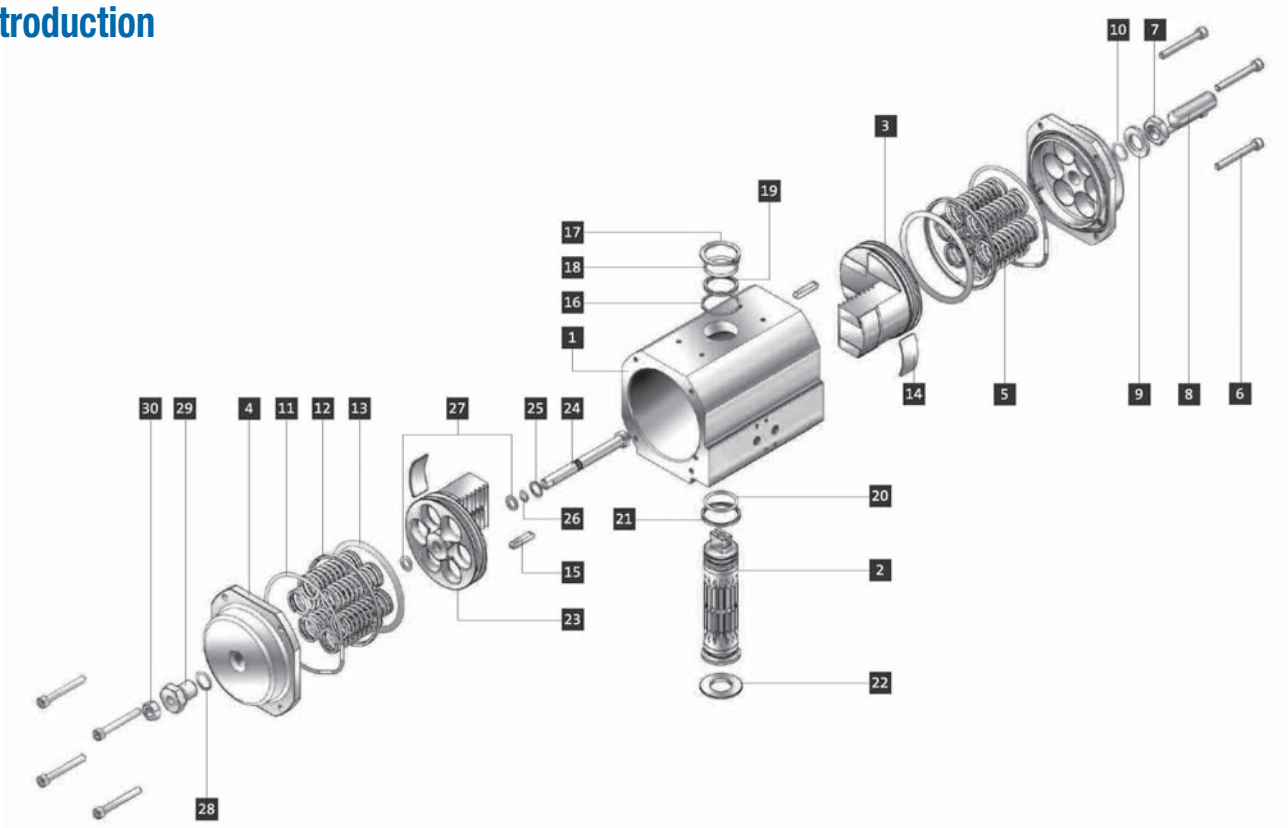

### STANDARDS

Gemels actuators are designed and in compliance with the following standards:

- ISO5211:** Orientation of actuator to valvemounting flange (i.e.F05,F07....)
- VDI/VDE 3845:** Namur mounting for accessories such as switchboxes, solenoid valves and positioners.
- ATEX:** ATEX Directive (94/9/CE).
- PED:** Pressure Equipment Directive (97/23/CE).

Ref No	Description	Qty	Material Std Unit	Comments
1	Body	1	Aluminium Anod.	
2	Driveshaft	1	Steel	Alt. CNI 425
3	Piston	2	Aluminium	Alt. Hard Anodized/PTFE
4	Endcap with Stop Adj.	2	Aluminium Anod.	
5	Spring	12 max	SiCr	S1 Double Acting only
6	Endcap Bolt	8	Stainless Steel	
7	Open Stop Adj. Bolt	1	Stainless Steel	
8	Open Stop Adj. Nut	1	Stainless Steel	
9	Open Stop Adj. Washer	1	Polyethylene	
10	Open Stop Adj. O'Ring	1	Buna Nitrile	Alt. Viton/Silicone/EPDM
11*	Endcap O'Ring	2	Buna Nitrile	Alt. Viton/Silicone/EPDM
12*	Piston Back-up Bearing	2	POM Delrin	
13*	Piston O'Ring	2	Buna Nitrile	Alt. Viton/Silicone/EPDM
14*	Piston Wearpad	2	POM Delrin	
15*	Piston Guidebar	2	Steel	
16*	Driveshaft Washer	1	Polyethylene	
17*	Driveshaft Circlip	1	Steel	
18*	Driveshaft Upper O'Ring	1	Buna Nitrile	Alt. Viton/Silicone/EPDM
19*	Driveshaft Upper Bearing	1	POM Delrin	
20*	Driveshaft Lower O'Ring	1	Buna Nitrile	Alt. Viton/Silicone/EPDM
21*	Driveshaft Lower Bearing	1	POM Delrin	
22	Centralization Ring	1	POM Delrin	
23 (G10)	Piston (Closed Stop Adj.)	1	Aluminium	Alt. Hard Anodized/PTFE
24 (G10)	Closed Stop Adj. Bolt	1	Stainless Steel	
25 (G10)	Closed Stop Adj. Damper	1	POM Delrin	
26 (G10)	Stop Bolt O'Ring	1	Buna Nitrile	Alt. Viton/Silicone/EPDM
27 (G10)	Piston Stop Bolt O'Ring	2	Buna Nitrile	Alt. Viton/Silicone/EPDM
28 (G10)	Stop Bolt Retainer O'Ring	1	Buna Nitrile	Alt. Viton/Silicone/EPDM
29 (G10)	Stop Bolt Retainer	1	Stainless Steel	
30 (G10)	Closed Stop Adj. Nut	1	Stainless Steel	



# + Actuators

Specialist in Ball Valves

## Double Acting

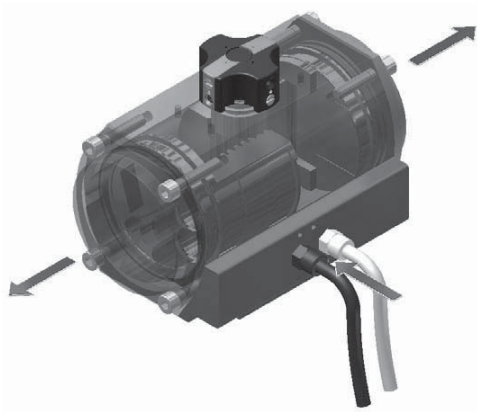

### Opening Stroke:

- Looking at the front of the Actuator, PORT 'A' is on the left and PORT 'B' is on the right.
- To open the Actuator, connect the air supply to PORT 'A' to fill the central chamber of the Actuator.
- The two opposing Pistons will open and rotate the driveshaft in a counter-clockwise direction.
- When the pistons reach the end of their travel, the actuator driveshaft will be in the open position.

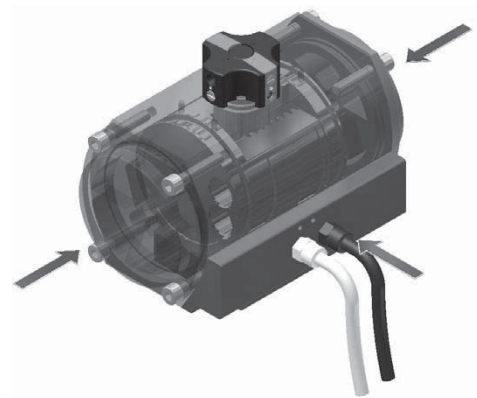

### Closing Stroke:

- Looking at the front of the Actuator, PORT 'A' is on the left and PORT 'B' is on the right.
- To close the Actuator, connect the air supply to PORT 'B' to fill the outer chambers of the Actuator.
- The two opposing Pistons will close and rotate the actuator driveshaft in a clockwise direction.
- When the pistons reach the end of their travel, the actuator driveshaft will be in the closed position.

# + Actuators

## Torque Value Gemels Actuators

## Double Acting

Torque Diagram Double Acting Actuator

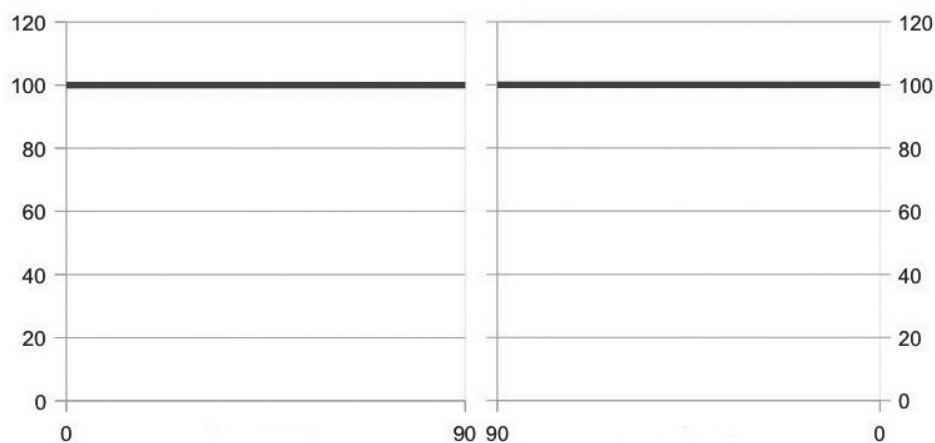

With reference to the above diagram, is possible to note that the torque of a double acting actuator remain constant through-out the complete action.

## Newton Metre

Actuator	AIR SUPPLY (Barg)						
	2	3	4	5	5,5	6	7
DA25 GD A3	7,9	11,9	15,8	19,8	21,7	23,7	27,7
DA100 GD A10	33,8	50,7	67,6	84,5	93,0	101,4	118,3
DA375 GD A35	125,0	187,0	249,0	312,0	343,0	374,0	437,0
DA825 GD A70	275,0	412,0	550,0	687,0	756,0	825,0	962,0

# + Actuators

Specialist in Ball Valves

## Spring Return

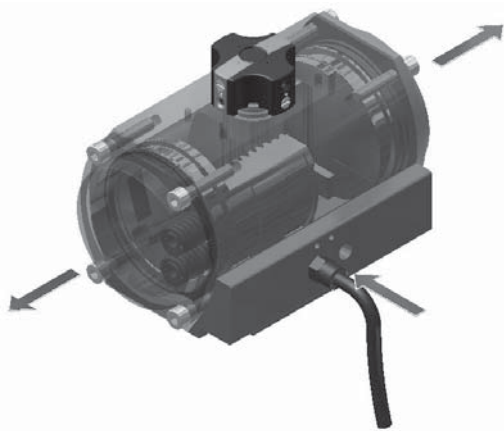

### Opening Stroke:

- Looking at the front of the Actuator, PORT 'A' is on the left and PORT 'B' is on the right.
- To open the Actuator, connect the air supply to PORT 'A' to fill the central chamber of the Actuator.
- The two opposing Pistons will open, compressing the springs in the outer chambers and rotate the driveshaft in a counter-clockwise direction.
- When the pistons reach the end of their travel, the springs will be fully compressed and the actuator driveshaft will be in the open position.

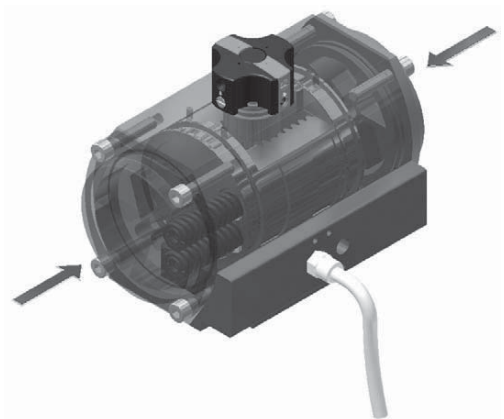

### Closing Stroke:

- Looking at the front of the Actuator, PORT 'A' is on the left and PORT 'B' is on the right.
- To close the Actuator, disconnect the air supply from PORT 'A'. This will allow the compressed springs to push the pistons back to their starting position.
- As the springs decompress the two opposing Pistons will close and rotate the actuator driveshaft in a clockwise direction.
- When the pistons reach the end of their travel, the actuator driveshaft will be in the closed position.

# + Actuators

## Torque Value Gemels Actuators

## Spring Return

0 Torque Diagram Spring Return actuator

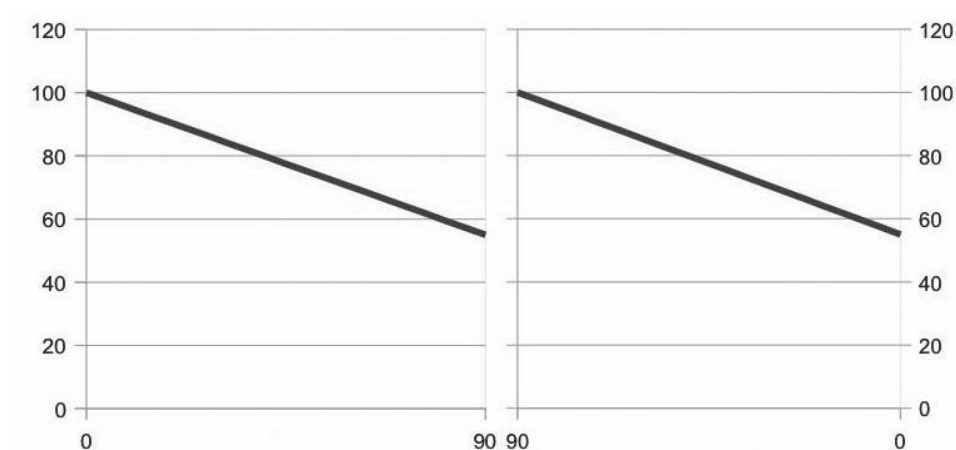

With reference to the above diagram the torque of a Spring Return actuator is not constant but decreasing. This is due to the action of the springs.

Model	N.Spring		Spring Torque		AIR SUPPLY (Barg)							
	Outer	Inner	0°	90°	4 Barg		5 Barg		5,5 Barg		6 Barg	
					90°	0°	90°	0°	90°	0°	90°	0°
SR25 TT3	8		5,36	10,48	10,40	5,30	14,40	9,30	16,40	11,20	18,30	13,20
	10		6,70	13,10			13,10	6,70	15,00	8,60	17,00	10,60
	11		7,37	14,41					14,40	7,30	16,30	9,30
	12		8,04	15,72					13,70	6,00	15,70	8,00
SR100 TT10	8		26,72	40,96	40,90	26,60	57,80	43,50	66,20	52,00	74,70	60,40
	10		33,40	51,20			51,10	33,30	59,60	41,80	68,00	50,20
	11		36,74	56,32					56,20	36,60	64,70	45,10
	12		40,08	61,44					52,90	31,50	61,30	40,00
SR375 TT35	4	0	88,40	160,80	161,00	88,70	223,40	151,00	254,60	182,20	285,70	213,40
	4	2	110,50	201,00	138,90	48,50	201,30	110,80	232,50	142,00	263,60	173,20
	4	3	121,60	221,10			190,20	90,70	221,40	121,90	252,60	153,10
	4	4	132,60	241,20			179,20	70,60	210,40	101,80	241,50	133,00
SR825 TT70	4	0	195,0	354,0	355,0	196,0	493,0	333,0	561,0	402,0	630,0	471,0
	4	2	243,0	443,0	306,0	107,0	444,0	245,0	513,0	314,0	581,0	382,0
	4	3	268,0	487,0			420,0	201,0	488,0	269,0	557,0	338,0
	4	4	292,0	531,0			395,0	156,	464,0	225,0	533,0	294,0

# + Actuators

Specialist in Ball Valves

## Solenoid Valve Mounting: Namur Type

Please ensure you read the IOM manual that is supplied with the solenoid valve in order to ensure correct function. This section is a guide to the function of a solenoid valve in conjunction with a pneumatic quarter turn actuator. The solenoid valves mentioned here are “**namur mounted**” with a modular “**5/2 way / 3/2 way**” (meaning either mode is possible with the same valve).

Certain facts need to be taken into consideration when mounting a namur solenoid valve to a quarter turn pneumatic actuator:

- Port “2” and “4” are always on the namur interface of the solenoid valve
- Port “2” and “4” are always connected to the namur interface of the quarter turn pneumatic actuator
- Port “1” is where instrument air is always connected to the solenoid valve
- Port “1” is always referred to as the air inlet or pressure port on a solenoid valve

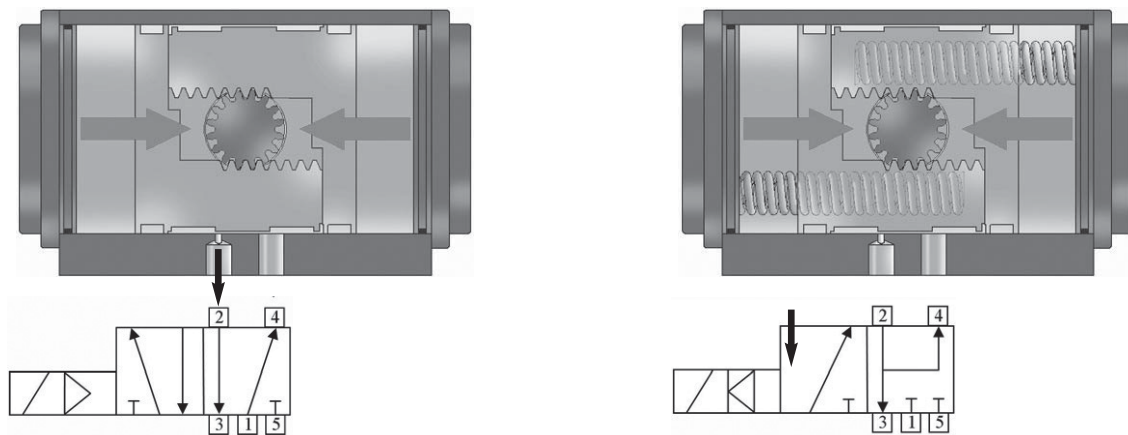

The above diagrams show a double acting actuator with 5/2 way solenoid valve (10.1) and a spring return actuator with a 5/2 way valve set up to function as a 3/2 way valve (10.2). Both valves are shown in the de-energised state (coil inactive, no electrical current). In both cases the solenoid valves port “2” is connected to the actuators port “A” through which air will vent out of port “3”. When connecting a namur solenoid valve, the pneumatic diagram will determine how to connect the ports. Only solenoid valve ports “2” and ‘4’ can be connected to the actuator. Whichever of the two ports shows a vertical arrow pointing away from it, is the port that needs to be connected to the actuators central chamber, in this case port “A”.



# + Actuators

## Operation with Solenoid Valves: Double Acting

Please ensure you read the IOM manual that is supplied with the solenoid valve in order to ensure correct function. This section is a guide to the function of a solenoid valve in conjunction with a pneumatic quarter turn actuator. The solenoid valves mentioned here are “**namur mounted**” with a modular “**5/2 way / 3/2 way**” (meaning either mode is possible with the same valve).

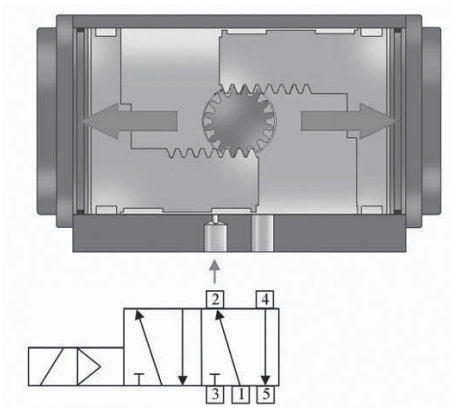

### Solenoid Coil Energised:

- This allows air to flow from solenoid inlet port “1” to solenoid port “2” which is connected to actuator port “A”
- As the air enters the center chamber of the actuator, the pistons start to move towards the open position (as indicated by the large red arrows).
- Atmospheric air from the outer chambers will vent out of actuator port “B”, which is connected to solenoid port “4” and the exhausts via solenoid port “5”.
- Solenoid port “3” is not used.

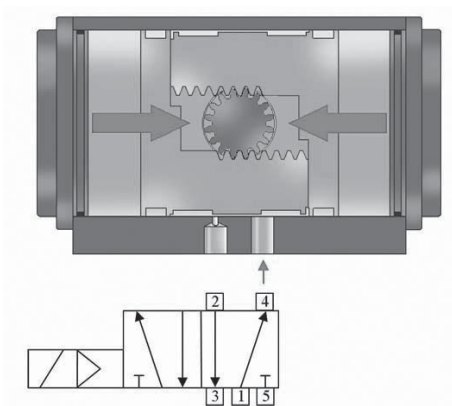

### Solenoid Coil De-Energised:

- This allows air to flow from solenoid inlet port “1” to solenoid port “4” which is connected to actuator port “B”
- As the air enters the outer chambers of the actuator, the pistons start to move towards the closed position (as indicated by the large red arrows).
- Atmospheric air from the inner chamber will vent out of actuator port “A”, which is connected to solenoid port “2” and the exhausts via solenoid port “3”.
- Solenoid port “5” is not used.

# + Actuators

Specialist in Ball Valves

## Operation with Solenoid Valves: Spring Return

Please ensure you read the IOM manual that is supplied with the solenoid valve in order to ensure correct function. This section is a guide to the function of a solenoid valve in conjunction with a pneumatic quarter turn actuator. The solenoid valves mentioned here are “**namur mounted**” with a modular “**5/2 way / 3/2 way**” (meaning either mode is possible with the same valve).

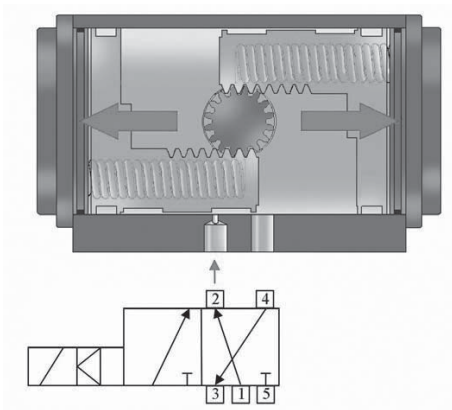

### Solenoid Coil Energised:

- This allows air to flow from solenoid inlet port “1” to solenoid port “2” which is connected to actuator port ‘A’
- As the air enters the center chamber of the actuator, the pistons start to move towards the open position and compressing the springs in the outer chambers (as indicated by the large red arrows).
- Atmospheric air from the outer chambers will vent out of actuator port “B”, which is connected to solenoid port “4” and then exhausts via solenoid port “3”.
- Solenoid port “5” is not used.

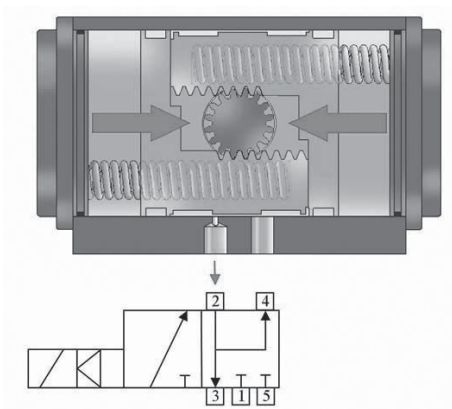

### Solenoid Coil De-Energised:

- This closes solenoid port “1” and stops inlet air from flowing.
- The springs in the outer chambers will move the pistons back to the closed position (as indicated by the large red arrows).
- Residual air from the inner chamber will vent out of actuator port “A”, which is connected to solenoid port “2” and the exhausts via solenoid port “3”.
- Solenoid port “5” is not used.
- Solenoid port “2” and port “4” are also connected in a loop so no dirty air may enter the actuator (this is available only on some solenoid valves).

# + Actuators

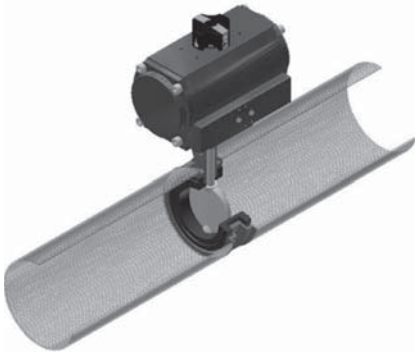

**13.1 in-line, closed position**

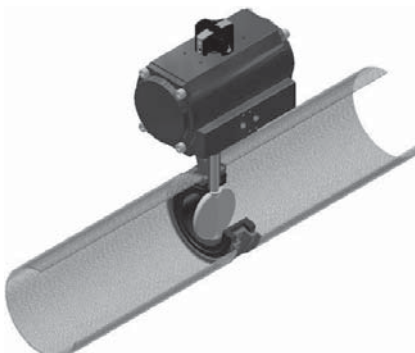

**13.2 in-line, open position**

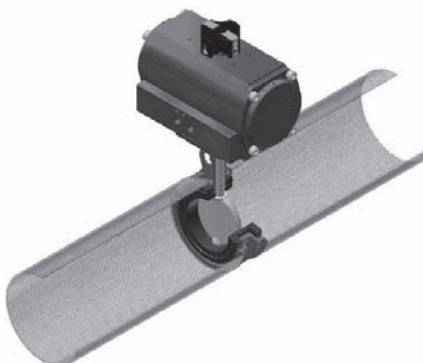

**13.3 crossmount, closed position**

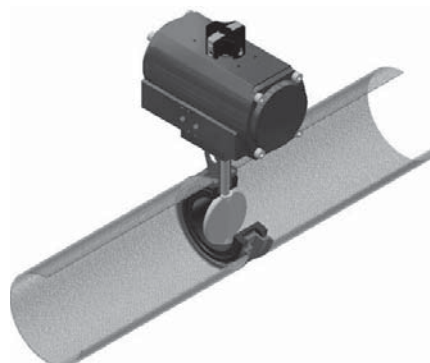

**13.4 crossmount, open position**

## Mounting Variations

Below are the two common variations to mounting a 90 degree or 180 degree actuator to a valve.

- 13.1** mounted **in-line** or **parallel** to the pipe, the actuator and valve are in the standard closed position
- 13.2** mounted **in-line** or **parallel** to the pipe, the actuator and valve are in the standard open position
- 13.3** mounted **crossmount** or **offset** to the pipe, the actuator and valve are in the standard closed position
- 13.4** mounted **crossmount** or **offset** to the pipe, the actuator and valve are in the standard open position

Mounting actuators in these varying positions is due to space constraints in the global assembly or simply due to consistency with prior assemblies already in existence. Please note how the indicator puck always correctly shows the position of the valve disc and hence showing the flowpath of the medium running through the pipe.

# + Actuators

Specialist in Ball Valves

## TORQUES (Nm) ACTUATOR GEMELS SEMPLY EFFECT

MODEL:	AIR SUPPLY														
	Springs	Spring Torque		3 Bar		4 Bar		5 Bar		5.5 Bar		6 Bar		7 Bar	
	Q.ty	Start	End	Start	End	Start	End	Start	End	Start	End	Start	End	Start	End
SR 25	1	1.31	0.67	11.2	10.5	15.1	14.5	19.1	18.4	21.1	20.4	23.0	22.4	27.0	26.3
	2	2.62	1.34	10.5	9.2	14.5	13.2	18.4	17.1	20.4	19.1	22.4	21.1	26.3	25.0
	3	3.93	2.01	9.8	7.9	13.8	11.9	17.7	15.8	19.7	17.8	21.7	19.8	25.6	23.7
	4	5.24	2.68	9.2	6.6	13.1	10.6	17.1	14.5	19.0	16.5	21.0	18.5	25.0	22.4
	5	6.55	3.35	8.5	5.3	12.5	9.3	16.4	13.2	18.4	15.2	20.4	17.2	24.3	21.1
	6	7.86	4.02	7.8	4.0	11.8	7.9	15.7	11.9	17.7	13.9	19.7	15.8	23.6	19.8
	7	9.17	4.69			11.1	6.6	15.1	10.6	17.0	12.6	19.0	14.5	23.0	18.5
	8	10.48	5.36			10.4	5.3	14.4	9.3	16.4	11.2	18.3	13.2	22.3	17.2
	9	11.79	6.03					13.7	8.0	15.7	9.9	17.7	11.9	21.6	15.9
	10	13.10	6.70					13.1	6.7	15.0	8.6	17.0	10.6	21.0	14.6
	11	14.41	7.37							14.4	7.3	16.3	9.3	20.3	13.2
	12	15.72	8.04							13.7	6.0	15.7	8.0	19.6	11.9
SR 50	1	2.72	1.50	23.9	22.6	32.3	31.1	40.8	39.5	45.0	43.8	49.2	48.0	57.7	56.4
	2	5.44	3.00	22.4	19.9	30.8	28.4	39.3	36.8	43.5	41.0	47.7	45.3	56.2	53.7
	3	8.16	4.50	20.9	17.2	29.3	25.6	37.8	34.1	42.0	38.3	46.2	42.5	54.7	51.0
	4	10.88	6.00	19.4	14.5	27.8	22.9	36.3	31.4	40.5	35.6	44.7	39.8	53.2	48.3
	5	13.60	7.50	17.9	11.8	26.3	20.2	34.8	28.7	39.0	32.9	43.2	37.1	51.7	45.6
	6	16.32	9.00	16.4	9.0	24.8	17.5	33.3	25.9	37.5	30.2	41.7	34.4	50.2	42.8
	7	19.04	10.50			23.3	14.8	31.8	23.2	36.0	27.4	40.2	31.7	48.7	40.1
	8	21.76	12.00			21.8	12.0	30.3	20.5	34.5	24.7	38.7	28.9	47.2	37.4
	9	24.48	13.50					28.8	17.8	33.0	22.0	37.2	26.2	45.7	34.7
	10	27.20	15.00					27.3	15.1	31.5	19.3	35.7	23.5	44.2	32.0
	11	29.92	16.50							30.0	16.6	34.2	20.8	42.7	29.2
	12	32.64	18.00							28.5	13.8	32.7	18.1	41.2	26.5
SR 100	1	5.12	3.34	47.4	45.6	64.3	62.5	81.2	79.4	89.6	87.8	98.1	96.3	115.0	113.2
	2	10.24	6.68	44.0	40.5	60.9	57.4	77.8	74.3	86.3	82.7	94.7	91.2	111.6	108.1
	3	15.36	10.02	40.7	35.3	57.6	52.2	74.5	69.1	82.9	77.6	91.4	86.0	108.3	102.9
	4	20.48	13.36	37.3	30.2	54.2	47.1	71.1	64.0	79.6	72.5	88.0	80.9	104.9	97.8
	5	25.60	16.70	34.0	25.1	50.9	42.0	67.8	58.9	76.3	67.4	84.7	75.8	101.6	92.7
	6	30.72	20.04	30.7	20.0	47.6	36.9	64.5	53.8	72.9	62.2	81.4	70.7	98.3	87.6
	7	35.84	23.38			44.2	31.8	61.1	48.7	69.6	57.1	78.0	65.6	94.9	82.5
	8	40.96	26.72			40.9	26.6	57.8	43.5	66.2	52.0	74.7	60.4	91.6	77.3
	9	46.08	30.06					54.4	38.4	62.9	46.9	71.3	55.3	88.2	72.2
	10	51.20	33.40					51.1	33.3	59.6	41.8	68.0	50.2	84.9	67.1
	11	56.32	36.74							56.2	36.6	64.7	45.1	81.6	62.0
	12	61.44	40.08							52.9	31.5	61.3	40.0	78.2	56.9

= Standard actuator.

### NOTE:

For a continuous improvement, Gemels reserves the right to operate changes without prior notice.

For the values highlighted, or are missing, or with a minus sign (-), it is reported that with the number of standard springs, at 3 bar, the actuator is not able to overcome the force of the internal springs, therefore the actuator can not to perform one complete rotation. Therefore with air supply of 3 Bar, it will be necessary evaluate the reduction of the number of springs or buy a bigger model.

# + Actuators

## TORQUES (Nm) ACTUATOR GEMELS SEMPLY EFFECT

MODEL:	AIR SUPPLY															
	Springs Q.ty		Spring Torque		3 Bar		4 Bar		5 Bar		5.5 Bar		6 Bar		7 Bar	
	Outer	Inner	Start	End	Start	End	Start	End	Start	End	Start	End	Start	End	Start	End
SR 200	1	0	21.7	11.9	89.0	79.3	122.7	112.9	156.3	146.6	173.2	163.4	190.0	180.2	223.7	213.9
	1	1	32.6	17.9	83.1	68.4	116.7	102.1	150.4	135.7	167.2	152.6	184.0	169.4	217.7	203.0
	2	0	43.4	23.9	77.1	57.6	110.8	91.2	144.4	124.9	161.2	141.7	178.1	158.5	211.7	192.2
	2	1	54.3	29.8	71.1	46.7	104.8	80.4	138.4	114.0	155.3	130.9	172.1	147.7	205.8	181.3
	2	2	65.1	35.8	65.2	35.9	98.8	69.5	132.5	103.2	149.3	120.0	166.1	136.8	199.8	170.5
	3	0	65.1	35.8	65.2	35.9	98.8	69.5	132.5	103.2	149.3	120.0	166.1	136.8	199.8	170.5
	3	1	76.0	41.8	59.2	25.0	92.9	58.7	126.5	92.3	143.3	109.2	160.2	126.0	193.8	159.6
	3	2	86.8	47.7	53.2	14.2	86.9	47.8	120.5	81.5	137.4	98.3	154.2	115.1	187.9	148.8
	3	3	97.7	53.7	47.3	3.3	80.9	37.0	114.6	70.6	131.4	87.5	148.2	104.3	181.9	137.9
	4	0	86.8	47.7	53.2	14.2	86.9	47.8	120.6	81.5	137.4	98.3	154.2	115.1	187.9	148.8
	4	1	97.7	53.7	47.3	3.3	80.9	37.0	114.6	70.6	131.4	87.5	148.2	104.3	181.9	137.9
	4	2	108.5	59.7	41.3	-7.5	75.0	26.1	108.6	59.8	125.4	76.6	142.3	93.4	175.9	127.1
	4	3	119.4	65.6	35.3	-18.4	69.0	15.3	102.6	48.9	119.5	65.8	136.3	82.6	170.0	116.2
	4	4	130.2	71.6	29.4	-29.2	63.0	4.4	96.7	38.1	113.5	54.9	130.3	71.7	164.0	105.4
SR 375	1	0	40.2	22.1	165.0	146.9	227.3	209.3	289.7	271.6	320.9	302.8	352.1	334.0	414.4	396.3
	1	1	60.3	33.2	153.9	126.8	216.3	189.2	278.7	251.5	309.8	282.7	341.0	313.9	403.4	376.2
	2	0	80.4	44.2	142.9	106.7	205.2	169.1	267.6	231.4	298.8	262.6	330.0	293.8	392.3	356.1
	2	1	100.5	55.3	131.8	86.6	194.2	149.0	256.5	211.3	287.7	242.5	318.9	273.7	381.3	336.0
	2	2	120.6	66.3	120.8	66.5	183.1	128.9	245.5	191.2	276.7	222.4	307.9	253.6	370.2	315.9
	3	0	120.6	66.3	120.8	66.5	183.1	128.9	245.5	191.2	276.7	222.4	307.9	253.6	370.2	315.9
	3	1	140.7	77.4	109.7	46.4	172.1	108.8	234.4	171.1	265.6	202.3	296.8	233.5	359.2	295.8
	3	2	160.8	88.4	98.7	26.3	161.0	88.7	223.4	151.0	254.6	182.2	285.8	213.4	348.1	275.7
	3	3	180.9	99.5	87.6	6.2	150.0	68.6	212.3	130.9	243.5	162.1	274.7	193.3	337.1	255.6
	4	0	160.8	88.4	98.7	26.3	161.0	88.7	223.4	151.0	254.6	182.2	285.7	213.4	348.1	275.7
	4	1	180.9	99.5	87.6	6.2	150.0	68.6	212.3	130.9	243.5	162.1	274.7	193.3	337.1	255.6
	4	2	201.0	110.5	76.6	-13.9	138.9	48.5	201.3	110.8	232.5	142.0	263.6	173.2	326.0	235.5
	4	3	221.1	121.6	65.5	-34.0	127.9	28.4	190.2	90.7	221.4	121.9	252.6	153.1	315.0	215.4
	4	4	241.2	132.6	54.5	-54.1	116.8	8.3	179.2	70.6	210.4	101.8	241.5	133.0	303.9	195.3

 = Standard actuator.

### NOTE:

For a continuous improvement, Gemels reserves the right to operate changes without prior notice.  
For the values highlighted, or are missing, or with a minus sign (-), it is reported that with the number of standard springs, at 3 bar, the actuator is not able to overcome the force of the internal springs, therefore the actuator can not to perform one complete rotation. Therefore with air supply of 3 Bar, it will be necessary evaluate the reduction of the number of springs or buy a bigger model.

# + Actuators

Specialist in Ball Valves

## TORQUES (Nm) ACTUATOR GEMELS SEMPLY EFFECT

MODEL:	AIR SUPPLY															
	Springs Q.ty		Spring Torque		3 Bar		4 Bar		5 Bar		5.5 Bar		6 Bar		7 Bar	
	Outer	Inner	Start	End	Start	End	Start	End	Start	End	Start	End	Start	End	Start	End
SR 580	1	0	64.1	35.3	263.1	234.3	362.6	333.7	462.0	433.2	511.8	482.9	561.5	532.6	660.9	632.1
	1	1	96.2	52.9	245.5	202.2	344.9	301.7	444.4	401.1	494.1	450.9	543.8	500.6	643.3	600.0
	2	0	128.2	70.5	227.9	170.2	327.3	269.6	426.8	369.1	476.5	418.8	526.2	468.5	625.7	568.0
	2	1	160.3	88.1	210.2	138.1	309.7	237.6	409.1	337.0	458.9	386.8	508.6	436.5	608.1	535.9
	2	2	192.3	105.8	192.6	106.1	292.1	205.5	391.5	305.0	441.2	354.7	491.0	404.4	590.4	503.9
	3	0	192.3	105.8	192.6	106.1	292.1	205.5	391.5	305.0	441.3	354.7	491.0	404.4	590.4	503.9
	3	1	224.4	123.4	175.0	74.0	274.4	173.5	373.9	272.9	423.6	322.7	473.3	372.4	572.8	471.8
	3	2	256.4	141.0	157.4	42.0	256.8	141.4	356.3	240.9	406.0	290.6	455.7	340.3	555.2	439.8
	3	3	288.5	158.6	139.7	9.9	239.2	109.4	338.6	208.8	388.4	258.6	438.1	308.3	537.5	407.7
	4	0	256.4	141.0	157.4	42.0	256.8	141.4	356.3	240.9	406.0	290.6	455.7	340.3	555.2	439.8
	4	1	288.5	158.6	139.7	9.9	239.2	109.4	338.6	208.8	388.4	258.6	438.1	308.3	537.6	407.7
	4	2	320.5	176.3	122.1	-22.1	221.6	77.3	321.0	176.8	370.7	226.5	420.5	276.2	519.9	375.7
	4	3	352.6	193.9	104.5	-54.2	203.9	45.3	303.4	144.7	353.1	194.5	402.8	244.2	502.3	343.6
	4	4	384.6	211.5	86.8	-86.2	186.3	13.2	285.8	112.7	335.5	162.4	385.2	212.1	484.7	311.6
SR 825	1	0	89	49	364	324	501	461	639	599	707	668	776	736	914	874
	1	1	133	73	339	280	477	417	614	555	683	623	752	692	889	829
	2	0	177	97	315	235	452	373	590	510	659	579	727	648	865	785
	2	1	221	122	291	191	428	329	566	466	634	535	703	603	841	741
	2	2	266	146	266	147	404	284	541	422	610	491	679	559	816	697
	3	0	266	146	266	147	404	284	541	422	610	491	679	559	816	697
	3	1	310	170	242	103	379	240	517	378	586	446	654	515	792	652
	3	2	354	195	218	58	355	196	493	333	561	402	630	471	767	608
	3	3	398	219	193	14	331	152	468	289	537	358	606	426	743	564
	4	0	354	195	218	58	355	196	493	333	561	402	630	471	768	608
	4	1	398	219	193	14	331	152	468	289	537	358	606	426	743	564
	4	2	443	243	169	-30	306	107	444	245	513	314	581	382	719	520
	4	3	487	268	145	-74	282	63	420	201	488	269	557	338	694	475
	4	4	531	292	120	-119	258	19	395	156	464	225	533	294	670	431

 = Standard actuator.

### NOTE:

For a continuous improvement, Gemels reserves the right to operate changes without prior notice.

For the values highlighted, or are missing, or with a minus sign (-), it is reported that with the number of standard springs, at 3 bar, the actuator is not able to overcome the force of the internal springs, therefore the actuator can not to perform one complete rotation. Therefore with air supply of 3 Bar, it will be necessary evaluate the reduction of the number of springs or buy a bigger model.

# + Actuators

[www.gemels.it](http://www.gemels.it)

## TORQUES (Nm) ACTUATOR GEMELS DOUBLE EFFECT

MODEL	AIR SUPPLY					
	3 Bar	4 Bar	5 Bar	5.5 Bar	6 Bar	7 Bar
DA 25	11.9	15.8	19.8	21.7	23.7	27.7
DA 50	25.4	33.8	42.3	46.5	50.7	59.2
DA 100	50.7	67.6	84.5	93.0	101.4	118.3
DA 200	101.0	134.6	168.3	185.1	201.9	235.6
DA 375	187	249	312	343	374	437
DA 580	298	398	497	547	597	696
DA 825	412	550	687	756	825	962

# + Actuators

[www.gemels.it](http://www.gemels.it)

2015 - Edition 1

## **WARNING: NEVER DISASSEMBLE A PRESSURISED UNIT!**

**Always isolate the actuator pneumatically  
or hydraulically and electrically.**

**Always remove all accessories  
and mounting hardware prior to maintenance.**

### Other Information

Actuator Lubricant: BERULUB FR16  
Spring Lubrications: VALVOLINE L-EP2

Always insure you wear the correct safety equipment as stipulated  
by your local organisation and applicable laws.